

Un socio estratégico que agrega valor

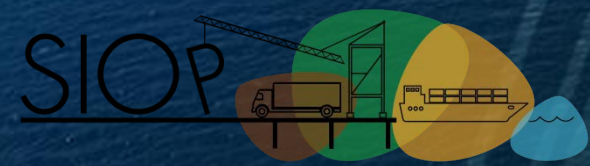

VIII Seminario Internacional de Ingeniería y Operación Portuaria | 2018

Talcahuano | Puertos para el futuro



Quienes somos



Nuestra Historia



Propuesta de Valor:



Excelente ubicación geográfica



Bahía protegida de aguas calmas



Inversión en infraestructura



Layout & Facilities



Equipamiento especializado



Servicios a la carga (Cfs) y logísticos



Innovación al servicio de nuestros usuarios & clientes



Compromiso de nuestros colaboradores

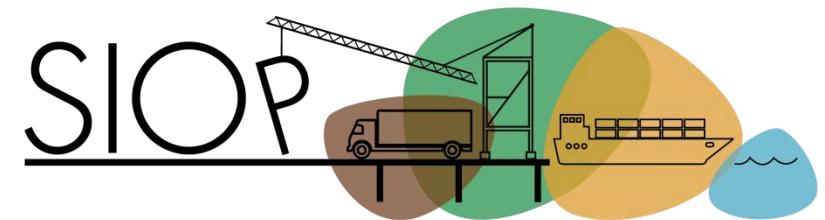

VIII Seminario Internacional de Ingeniería y Operación Portuaria | 2018

Talcahuano

Puertos para el futuro

Quienes Somos



50%

Empresa con más de 60 años de experiencia en manejo de carga en Terminales Portuarios

- Mas de 250 Terminales alrededor del mundo
- 113 millones de toneladas transferidas al año.
- 27 millones de teus al año.

50%



Empresa con más de 50 años de experiencia, presente en 13 países del Norte, Centro y Sur de América.

- 11 Terminales Portuarios
- 39.7 millones de toneladas transferidas al año
- 3.2 millones de teus al año.

Nuestra Historia

2000

1ero de enero inicio de concesión



2003

Construcción de explanada Rompeolas (4 hectáreas)

2005

Dragado Sitio 2, 3.



2008

Extension de Concesión

2010

27/F Terremoto, desarme Bodega 3.



2015

Construcción Bodega 8 (8.900m²). Obras de enrocado, explanada Norte.

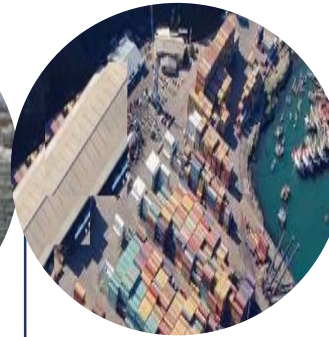

2016

Termino Construcción Sitio 4 y 5 Explanada Sur



Propuesta de valor



VIII Seminario Internacional de
Ingeniería y Operación Portuaria | 2018

Talcahuano | Puertos para el futuro

Excelente ubicación geográfica

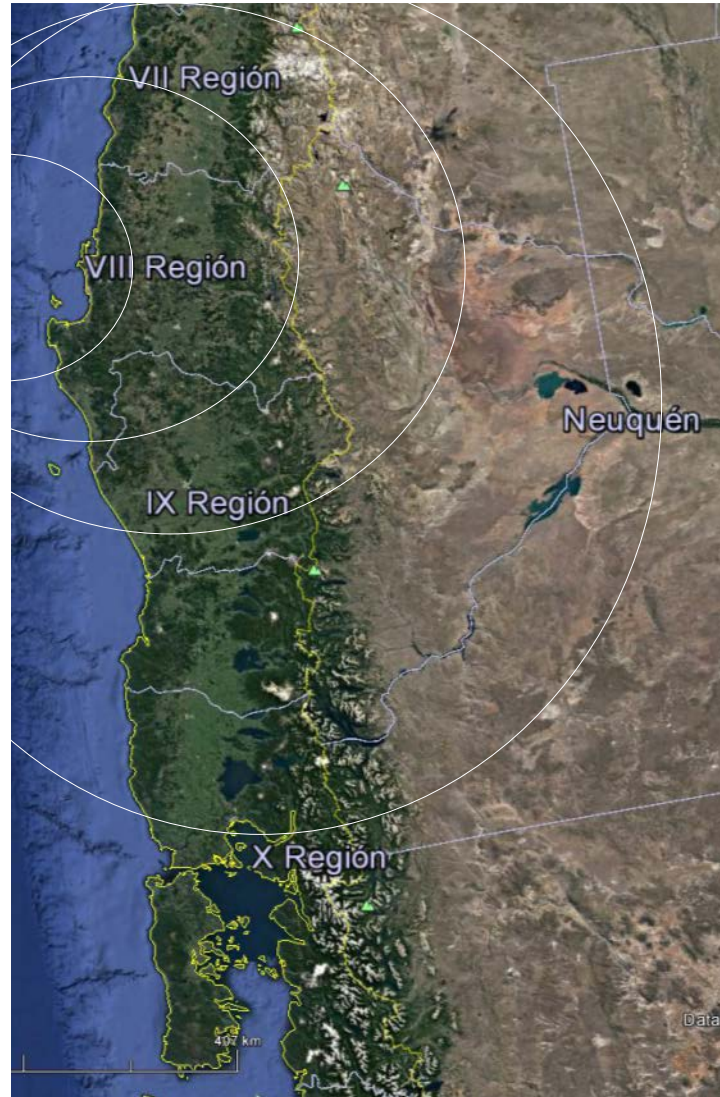

Access to Road 5:

- Itata Road (Chillan to North) 90km
- Cabrero Road (Los Angeles to South) 90km

Distances to Production Zone : North

- Talca 260 km
- Linares 220km
- Chillan 100 km

Distances to Production Zone : South

- Cabrero 90 km
- Los Angeles 140km
- Arauco 83 km
- Temuco 310 km
- Osorno 550 km
- Puerto Montt 650 km
- Castro 815 km

Distances to Production Zone : Argentina

- Neuquen 715 km

Bahía protegida de aguas calmas

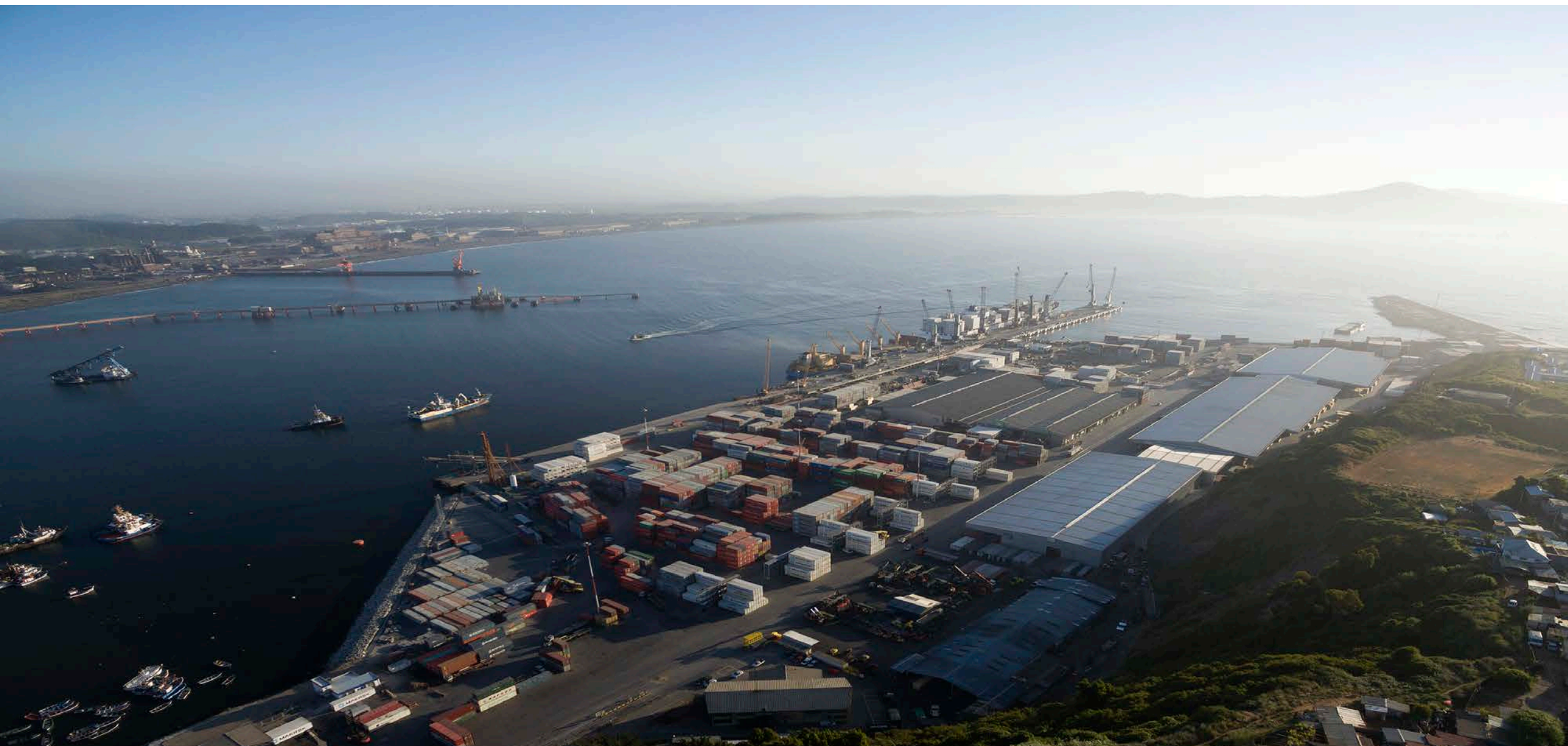

Proyecto de expansión: Sitios 4 & 5



Proyecto de expansión: Sitios 4 & 5

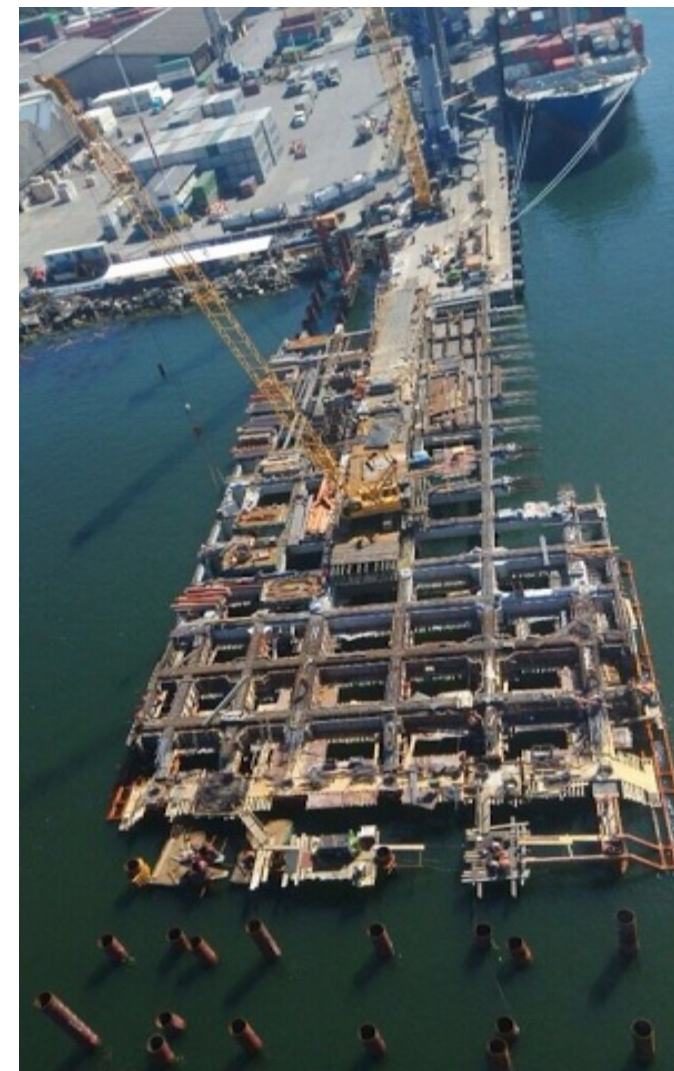

Inversión en bodegas especializadas



Sala de inspección de carga refrigerada



Layout & Facilities



DRAFT:
Berth 1: 12,1 mts
Berth 2: 12,1 mts
Berth 3: 14,02 mts
Berth 4: 14,02 mts
Berth 5: 12,02 mts



LENGHT:
160 mts bulk
210 mts multipurpose
704 mts Container
Total Lenght: 1074 mts



WAREHOUSE & CFS:
Storage capacity: 51000 M2



STACKING:
Stacking capacity: 15000 containers



CONTAINER DEPOT & WORKSHOP



REEFER CONTAINER RACKS:



**FROZEN CARGO
INSPECTION CHAMBER**



**GATE CONTROL
Truck appoinment system**



RAILWAY CONNECTION



**HAZARDOUS & DANGEROUS
CARGO DEPOT**

Equipmientto



2 Gantry Cranes



9 MHC



40 TRUCK



15 STACKER



Forklifts



450 + Reefer Plugs



2 Ecologic Hopper

(2) Nuevas Grúas Pórtico Cranes

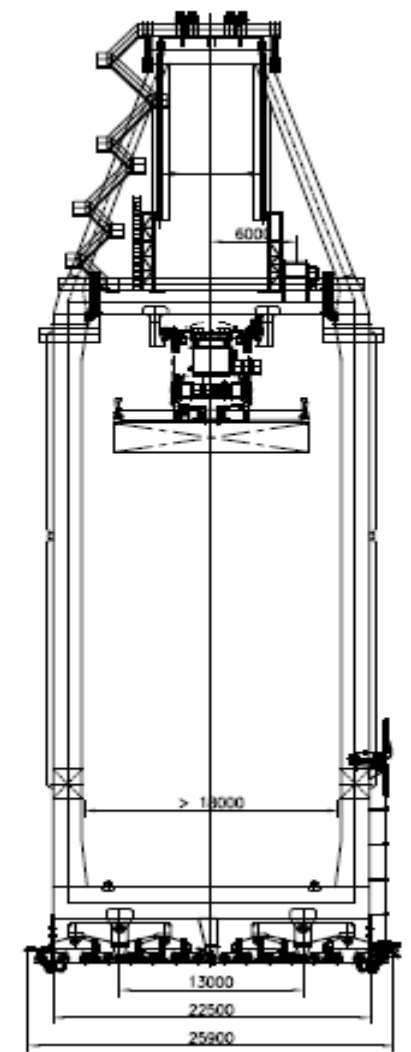
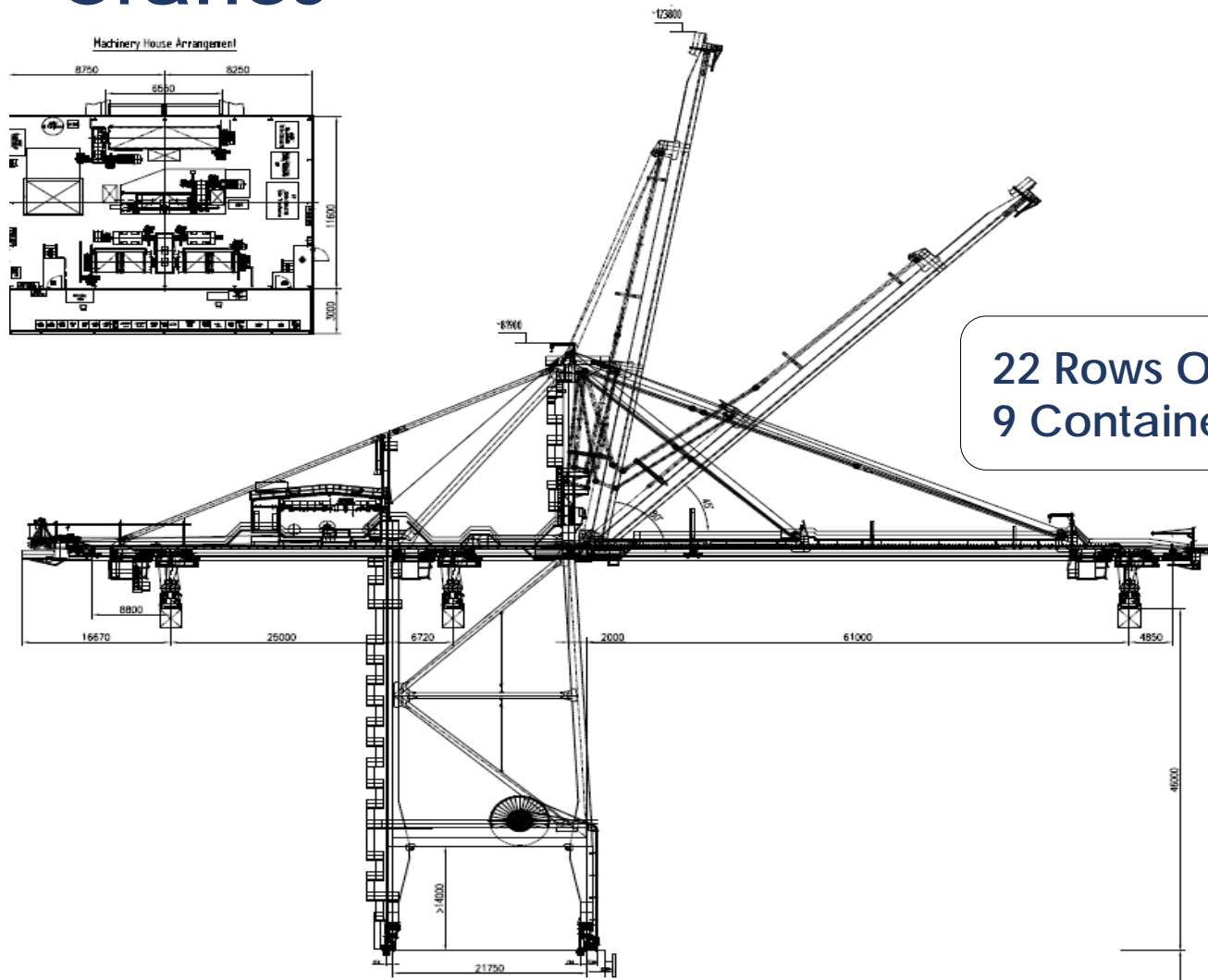

Servicios a la carga (CFS) y Logísticos



Container Express

¿QUÉ ES CONTAINER EXPRESS?

Container express es una plataforma innovadora y tecnológica al servicio de los usuarios del comercio exterior. Creada para apoyar sus procesos logísticos y de planificación de entrega y retiro de sus contenedores en SVTI.



CONTAINER EXPRESS EXPORTACIONES

A través del **STACKING PASS**
El Stacking Pass es el único documento válido para realizar la entrega de un contenedor de exportación en SVTI.



[Ingrese Aquí](#)

CONTAINER EXPRESS IMPORTACIONES

A través del **STACKING PASS**
El Stacking Pass es el único documento válido para realizar el retiro de un contenedor de importación en SVTI.



[Ingrese Aquí](#)

Trabajadores comprometidos



Clientes

Containers & CFS



Break Bulk



Bulk



CONSORCIO MADERERO S.A



FORESTAL COMACO S.A.

Conectamos Bio Bio & Chile con el Mundo



Gracias por su atención



VIII Seminario Internacional de Ingeniería y Operación Portuaria | 2018

Talcahuano | Puertos para el futuro